

REAL SOLUTIONS TO STUDIO LIGHTING

3BL655

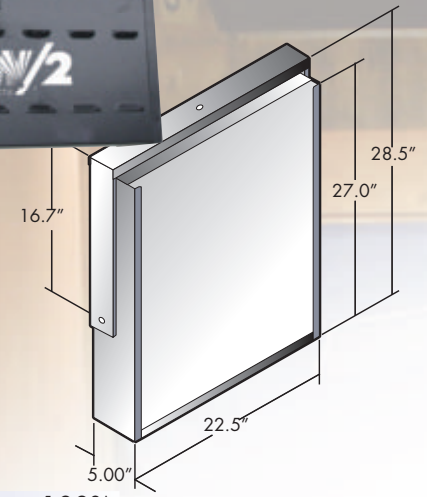

Why KW2 Technology?

- More light, not heat.**
Stop melting the talent.
- Spectacular images – every day**
Color balanced.
10,000 Lamp hours.
No lamp adjustment or replacement for years.
- Lower operational cost**
Reduced - lamp inventory.
- lamp maintenance.
Lower - power consumption.
- air conditioning bills.
- No new power**
Refit to existing electrical circuits.
- Total control**
All Dimming types available.
Fully accessorized.
- No flicker.**
- No noise.**

**SOFT FILL
6 lamp, maximum power.**

Power Control

FUL Standard	100%
Non dimming	
DIM Line Voltage	10-100%
Power line voltage controls intensity (2 wire dimming)	
DAN Analog	2-100%
Separate 0-10V Circuit controls intensity	
DNR Analog	0-100%
Includes relay shut-off for fade to black, 0-10V	
DMX Digital	0-100%
Fully digital, addressable and daisy chained	

Available Accessories



Honeycomb



Eggcrate wide only



Barndoor



Acrylic Lens



Gelframe



Bare

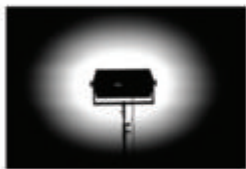

Wide



Medium



Narrow



214.393.5998
FAX:214.393.5999
www.kw2.com



Manufactured by PL Systems, Inc.
10529 Olympic Drive, Suite #102
Dallas, Texas 75220

Accessory List

BL6-45HC-GFC	Honeycomb Wide, black, includes gelframe
BL6-25HC-GFC	Honeycomb Medium, black, includes gelframe
BL6-17HC-GFC	Honeycomb Narrow, black, includes gelframe
BL6-45TC-C	Eggcrate Wide, black, NO gelframe
BL6-GFC	Gelframe only, black
BL6-AL	Acrylic lens
BL6-BDC	Black barn door
BL6-BHC	Black barn door with reflective inserts
2CC	2" Studio C Clamp
SCC	Safety cable
25BNC	25ft BNC cable
50BNC	50ft BNC cable

All Fixtures furnished with 12ft power cord
DAN & DNR furnished with 10ft BNC cable

Specifications

Weight	27 lbs., welded steel, Global directional adjustment
Power consumption	3.0 Amps @ 120V,60Hz (330 Watts)
Peak Candlepower	9,250 Candelas
Typical lamp output	6 @ 4,800 = 28,800 Lumens
Sound rating	>Class A
Start temperature	50 degrees F
Lamp type	Fluorescent twin tube, T5 triphosphor
Lamp frequency	25,000 Hz
Power factor	>0.95
Total harmonic distortion	<10%
Transient Protection	EMI Filter FCC Part18C Class A IEEE 587A (ANSI C62.41)
Beam Angle	@ 0 = 85, @ 90 = 100
Field Angle	@ 0 = 132, @ 90 = 130

Ordering Chart

55/830

Studio Lamps, 55W Twin

Catalog ID	Color Temp	CRI	Light output
55/830	3000K	82%	4800L
55/832*	3200K	85%	4000L
55/856*	5600K	85%	4000L
55/930	3000K	98%	3000L
55/950	5000K	98%	3000L

(Six lamps included with each fixture)

* Small upcharge for 832 and 856 lamps

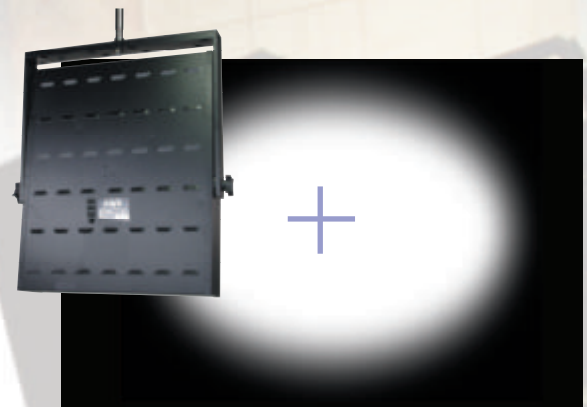

Foot-Candles At Center

6 Lamps	240	118	78	57
Distance	6'	9'	12'	15'

3BL655

C

FUL

120

Fixture Model

3BL655
Six lamp, Soft fill
at MAXIMUM
power

Color

C Black Housing
T White Housing
Other colors -
Contact factory

Dimming Options

FUL - Full power ballast
DIM - Line voltage dimming
DAN - 0-10V analog dimming
DNR - Fade-to-black, 0-10V dim
DMX - Digital dimming, DMX512
All Fixtures furnished with 12ft power cord
DAN & DNR furnished with 10ft BNC cable

Voltage & Cord Set

120: 120V, 5-15P (3 prong, 'Edison' cord set) Standard
120L5 120V, 5-15L (Twist-Lok, 15A)*
120PG 120V, P&G 3 pin studio plug*
230: 230V 50Hz, 12ft (3) conductor cord, no plug*
277: 277V, 12ft (3) conductor cord, no plug*
No on/off switch on 277V model
*Small upcharge for non-standard voltages or plug sets

Accent
Lights

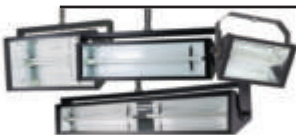

1BL255



2BL455



3BL655



Portable
Video



Conference



KW/2 PrimeTime
Lighting Systems™

214.393.5998
FAX: 214.393.5999
www.kw2.com

Manufactured by PL Systems, Inc.
10529 Olympic Drive, Suite #102
Dallas, Texas 75220